

Product Overview

Miniature Circuit Breaker

Model	Deluxe	Standard
Type	HGD63N, 63H, 125	HGD32NS, 63E, 63S, 63M, 63P, 63U, 100S
Breaking Capacity	6, 10 kA	3, 4.5, 6, 10, 15 kA
Pole	1, 2 (1+N), 3, 4 (3+N)	1, 2 (1+N), 3, 4 (3+N)
Rated Current	0.5~125 A	1~125 A
Tripping Curve	B, C, D	B, C, D
Standard	IEC/EN 60898-1, 60947-2	IEC/EN 60898-1, 60947-2



Miniature Switch Disconnecter

Model	Deluxe	Standard
Type	HSD63, HSD125	HSD100S
Utilization Category	AC22 A	AC22 A
Pole	1, 2, 3, 4	1, 2, 3, 4
Rated Current	16~125 A	16~100 A
Standard	IEC/EN 60947-3	IEC/EN 60947-3

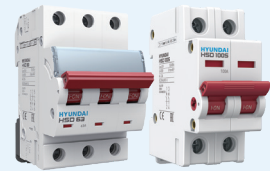

Residual Current Circuit Breaker

Model	Deluxe	Standard
Type	HRC63, HRC100	HRC63S, HRC100S
Operating Characteristics	AC, A	AC, A
Pole	2, 4	2, 4
Residual Current	30~500 mA	30~500 mA
Rated Current	16~125 A	16~125 A
Standard	IEC/EN 61008-1	IEC/EN 61008-1



Residual current Circuit Breaker with Overcurrent protection

Model	2 Module Type			RCD Type		Compact Type						
Type	HRO63S	HRO63A	HRO63B	HRO63M	HRO63P	HRO40L	HRO40T	HRO40HT	HRO40M	HRO40P	HRO40ML	HRO40PL
Breaking Capacity	4.5 kA	6 kA	10 kA	6 kA	10 kA	6 kA	6 kA	10 kA	6 kA	10 kA	6 kA	10 kA
Pole	1+N	2P		1, 2(1+N), 3, 4(3+N)		1+N			N+1			
Rated Current	1~63 A	6~63 A		1~63 A		6~40 A			6~40 A			
Operating Characteristics	AC, A	AC, A		AC, A		AC, A			AC, A			
Residual Current	10~500mA	30~300mA		10~500 mA		10~300 mA			10~300 mA			
Tripping Curve	B, C, D	B, C, D		B, C, D		B, C			B, C			
Standard	IEC/EN 61009-1											



Electronic Circuit Breaker

Model	HEC
Type	HEC20
Rated Current	2~20 A
Current Setting Interval	0.1 A
Pole	2
Overloading Cut-off Delay	10 sec



Molded Case Circuit Breaker (HBD Type)

Model	Plug-in		Lug-to-Lug	
	HBD51D~53D	HBD51hD~53hD	HBD51~53	HBD51h~53h
Type				
Breaking Capacity	5 kA	10 kA	5 kA	10 kA
Pole	1P~3P	1P~3P	1P~3P	1P~3P
Rated Current	10~50 A	10~50 A	10~50 A	10~50 A
Standard	IEC 60947-2			



Installation Contactor

Model	HIC
Type	HIC25, 40, 63
Rated Voltage (Ue)	2P: 230 V, 4P: 400 V
Pole	2P, 4P
Rated Current (Ie)	25 A, 40 A, 63 A
Rated Control Voltage (Uc)	24 V, 48 V, 230 V
Standard	IEC/EN 61095



Manual Motor Starter

Model	Rotary	Push Button	
Type	HMMS32R	HMMS32K	HMMS80K
Pole	3	3	3
Rated Current	0.1~32 A	0.1~32 A	25~80 A
Standard	IEC 60947-2, IEC 60947-4		



Surge Protection Device

Model	Din-rail Type	Box Type				
		Standard		Deluxe		
Type	HSP20	HSP13/25	HSP40S/80S	HSP120S/200S	HSP40H	HSP160H/320H
Pole	2,3(AC/DC),4(AC)	2,3,4	(2,3,4) W+G	(2,3,4) W+G	(2,3,4) W+G	(2,3,4) W+G
Class	II	I	II	I	II	I
Voltage Type	AC/DC	AC	AC	AC	AC	AC
In (8/20 μs) kA/Mode	20	-	20~40	-	20	-
Iimp (10/350 μs) kA/Mode	-	L-N: 12.5~25 N-PE: 50~100 L-PE: 12.5~25	-	6.5~12.5	-	L-N: 12.5~25 N-PE: 50~100 L-PE: 12.5~25
Standard	AC/DC: IEC 61643-11		AC: IEC 61643-11			



Low Voltage Fuse

Model	Fuse Link (Cylindrical Type)	Fuse Link (NT/NH Type)
Fuse Size	8 x 32, 10 x 38, 14 x 51, 22 x 58	00C, 00, 0, 1, 2, 3, 4
Rated Current	0.5~125 A	2~1,250 A
Fuse Holder/Switch	Fuse Holder (FH Type)	Fuse Switch (FS Type)



HMMS

Manual Motor Starter

Features	98
Selection Table	100
Accessories	102
Technical Data	104
Dimensions	109
Order Information	112

Features

HMMS Manual Motor Starter

Hyundai Manual Motor Starter, MMS series, realizes the function of molded case circuit breaker and thermal overload relay in one module. It enables perfect protection for overload, phase loss, short circuit and infrequent start control of 3-phase motors. MMS also can be used for the protection of distribution line as well as satisfied with the international standard IEC 60947-2 and IEC 60947-4-1.





Product Features

HYUNDAI ELECTRIC introduces the Rotary handle type of new MMS rating from 1 A to 32 A.

Function

- Phase-failure protection
- Short circuit protection
- Overload protection
- Frequent operation
- Disconnect switch

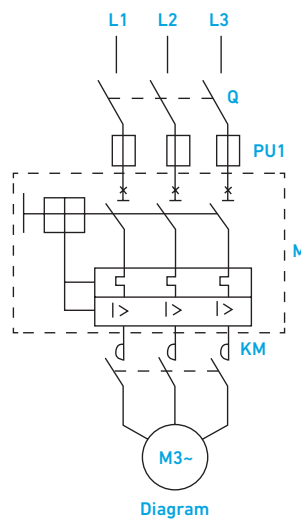

Features

- Standard: IEC 60947-2 / IEC 60947-4
- 50 % Less wiring: MCCB + Contactor + TOR -> MMS + Contactor
- Compact size: save 57 % space
- Green design: Recyclable plastic, no cadmium connection, RoHs
- Tool free installation: 35 mm Din-rail mounting



※ 44.5 mm width up to 32 AF, 61.2 mm width up to 80 AF.

Selection Table

HMMS Type

Model			HMMS32K										
													
Operation Type			Push-button										
No. of Poles			3										
Rated Current (In)			0.1~32 A										
Rated Operational Voltage (Ue)			Up to 690 V										
Rated Frequency (F)			50/60 Hz										
Rated Insulation Voltage (Ui)			690 V										
Rated Impulse Voltage (Uimp)			6 kV										
Utilization Category	IEC 60947-2 (Breaker)		Cat. A										
	IEC 60947-4 (Motor Starter)		AC 3										
Electrical/Mechanical Endurance (no. of Operations) Minimum			100,000/100,000										
Max Operating Frequency Per Hour (Ope./h)			25										
Temperature Compensation (Operation)			-20~+60 °C										
Instantaneous Short Circuit Release			13 × Ie max.										
Humidity			95% RH										
Altitude (m)			2,000										
Terminal Capacity (max)			10 mm ²										
Tightening Torque			2.5 N·m										
Function	Overload Protection		o										
	Phase Failure Protection		o										
	Test Button		o										
Weight (kg)			0.250										
Dimensions (H x D x W)			89.0 x 78.2 x 44.5										
Mounting			Clip in DIN Rail (35 mm x 7.5 mm)										
Installation Position			Vertical/Horizontal										
Options			AUX/AXT/SHT/UVT/Enclosure										
Rated Breaking Capacity (kA)	Rated Operational Current (Ie)	Setting Range (A)	AC220 V AC230 V AC240 V		AC400 V AC415 V		AC440 V AC460 V		AC500 V AC525 V		AC600 V AC690 V		
			Icu	Ics	Icu	Ics	Icu	Ics	Icu	Ics	Icu	Ics	
	0.16		0.1-0.16	100	100	100	100	100	100	100	100	100	100
	0.25		0.16-0.25	100	100	100	100	100	100	100	100	100	100
	0.4		0.25-0.4	100	100	100	100	100	100	100	100	100	100
	0.63		0.4-0.63	100	100	100	100	100	100	100	100	100	100
	1		0.63-1	100	100	100	100	100	100	100	100	100	100
	1.6		1-1.6	100	100	100	100	100	100	100	100	100	100
	2.5		1.6-2.5	100	100	100	100	100	100	100	3	2.25	
	4		2.5-4	100	100	100	100	100	100	100	3	2.25	
	6.3		4-6.3	100	100	100	100	50	50	50	50	3	2.25
	10		6-10	100	100	100	100	15	15	10	10	3	2.25
	14		9-14	100	100	15	7.5	8	4	6	4.5	3	2.25
	18		13-18	100	100	15	7.5	8	4	6	4.5	3	2.25
	23		17-23	50	50	15	6	6	3	4	3	3	2.25
	25		20-25	50	50	15	6	6	3	4	3	3	2.25
	32		24-32	50	50	10	5	6	3	4	3	3	2.25
	40		25-40	-	-	-	-	-	-	-	-	-	-
	63		40-63	-	-	-	-	-	-	-	-	-	-
	80		56-80	-	-	-	-	-	-	-	-	-	-

HMMS32R









Rotary										
3										
0.1~32 A										
Up to 690 V										
50/60 Hz										
690 V										
6k V										
Cat. A										
AC 3										
100,000/100,000										
25										
-20~+60 °C										
13 × Ie max.										
95% RH										
2,000										
10 mm ²										
2.5 N·m										
o										
o										
o										
0.277										
89.8 x 89.5 x 44.5										
Clip in DIN Rail (35 mm x 7.5 mm)										
Vertical/Horizontal										
AUX/AXT/SHT/UVT/Handle										
AC220 V AC230 V AC240 V	AC400 V AC415 V	AC440 V AC460 V	AC500 V AC525 V	AC600 V AC690 V						
Icu	Ics	Icu	Ics	Icu	Ics	Icu	Ics	Icu	Ics	
100	100	100	100	100	100	100	100	100	100	
100	100	100	100	100	100	100	100	100	100	
100	100	100	100	100	100	100	100	100	100	
100	100	100	100	100	100	100	100	100	100	
100	100	100	100	100	100	100	100	100	100	
100	100	100	100	100	100	100	100	100	100	
100	100	100	100	100	100	100	100	3	2.25	
100	100	100	100	100	100	100	100	3	2.25	
100	100	100	100	50	50	50	50	3	2.25	
100	100	100	100	15	15	10	10	3	2.25	
100	100	15	7.5	8	4	6	4.5	3	2.25	
100	100	15	7.5	8	4	6	4.5	3	2.25	
50	50	15	6	6	3	4	3	3	2.25	
50	50	15	6	6	3	4	3	3	2.25	
50	50	10	5	6	3	4	3	3	2.25	
-	-	-	-	-	-	-	-	-	-	
-	-	-	-	-	-	-	-	-	-	
-	-	-	-	-	-	-	-	-	-	

HMMS80K



Push-button										
3										
25~80 A										
Up to 690 V										
50/60 Hz										
690 V										
6 kV										
Cat. A										
AC 3										
30,000/50,000										
25										
-20~+60 °C										
13 × Ie max.										
95% RH										
2,000										
25 mm ²										
4.5 N·m										
o										
o										
o										
0.682										
120.0 x 113.0 x 61.2										
Clip in DIN Rail (35 mm x 7.5 mm)										
Vertical/Horizontal										
AUX										
AC220 V AC230 V AC240 V	AC400 V AC415 V	AC440 V AC460 V	AC500 V AC525 V	AC600 V AC690 V						
Icu	Ics	Icu	Ics	Icu	Ics	Icu	Ics	Icu	Ics	
-	-	-	-	-	-	-	-	-	-	
-	-	-	-	-	-	-	-	-	-	
-	-	-	-	-	-	-	-	-	-	
-	-	-	-	-	-	-	-	-	-	
-	-	-	-	-	-	-	-	-	-	
-	-	-	-	-	-	-	-	-	-	
-	-	-	-	-	-	-	-	-	-	
-	-	-	-	-	-	-	-	-	-	
-	-	-	-	-	-	-	-	-	-	
-	-	-	-	-	-	-	-	-	-	
-	-	-	-	-	-	-	-	-	-	
-	-	-	-	-	-	-	-	-	-	
-	-	-	-	-	-	-	-	-	-	
-	-	-	-	-	-	-	-	-	-	
100	100	50	25	50	25	10	5	5	3	
100	100	50	25	50	25	10	5	5	3	
100	100	15	7.5	10	6	4	4	2	2	

Accessories

Accessories	Ordering Information	Electrical Diagram	Contact	Category				Weight (g)
				Ui (AC/V)	Ue (V)	Ie (A)	VA	
Auxiliary Switch Front Mounting 	MMS32K AUX T11		1NO 1NC	250	240	2.5	120	16
	MMS32K AUX T20		2NO					
Auxiliary Switch Side Mounting 	MMS32K AUX S11		1NO 1NC	690	690	6	720	40
	MMS32K AUX S20	 AUX S11 AUX S20	2NO					
Auxiliary Switch Side Mounting 	MMS80K AUX S11		1NO 1NC	690	690	6	720	40
	MMS80K AUX S20	 AUX S11 AUX S20	2NO					
Failure Alarm Side Mounting 	MMS32K AXT 0110		Failure contact: NC Auxiliary contact: NC	690	240	2.5 (95-96 & 97-98) Failure contact	72	40
	MMS32K AXT 0101		Failure contact: NC Auxiliary contact: NC					
	MMS32K AXT 1010		Failure contact: NO Auxiliary contact: NO	690	690	6 (51-52 & 53-54) Auxiliary contact	720	
	MMS32K AXT 1001		Failure contact: NO Auxiliary contact: NC					
Shunt Trip Relay 	MMS32K SHT 110		Uc = 110 V, 50/60 Hz				90	
	MMS32K SHT 240		Uc = 220/240 V, 50/60 Hz					
	MMS32K SHT 380		Uc = 380 V, 50/60 Hz					
Under Voltage Trip Relay 	MMS32K UVT 110		Uc = 110 V, 50/60 Hz				90	
	MMS32K UVT 240		Uc = 220/240 V, 50/60 Hz					
	MMS32K UVT 380		Uc = 380 V, 50/60 Hz					

Enclosure

• MMS32K ENC

Case cover of MMS enclosure is specifically designed with dust-proof and corrosive-proof structure.

Therefore, it is the optimum product to use in dusty areas such as cement plants, cotton mills as well as in the presence of corrosive gas or liquid (ex: explosive, flammable gas) such as fertilizer, refinery, and plating plant.

- Operating temp.: -20 ~ +60 °C
- Degree of protection: IP55
- Conforming to standards: IEC 60947-2, IRC 60947-4-1
- Operational voltage U_e : 690 V
- Material: Polycarbonate

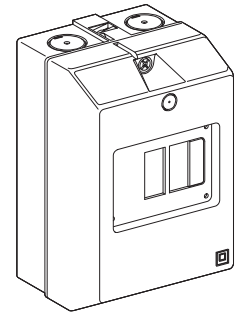

Extension Handle (TFH)

• TFH MMS32R

MMS extension handle is a rotary type handle accessory which can be attached to the front to control and verify the On, Trip, Off condition of manual.

Motor starters under the situation of closing panel.

- Application model: MMS32R
- Operating temp.: -20~+60 °C
- Degree of protection: IP65
- Locking device: Lockable in on/off position
- Material: PA66

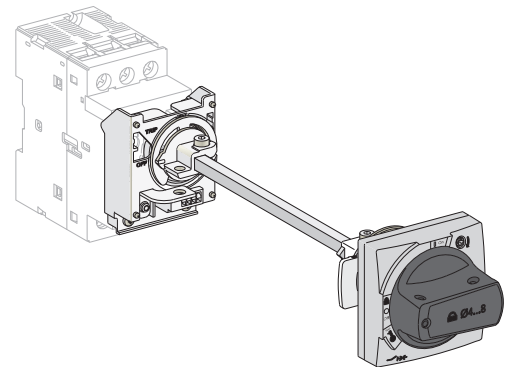

Mounting

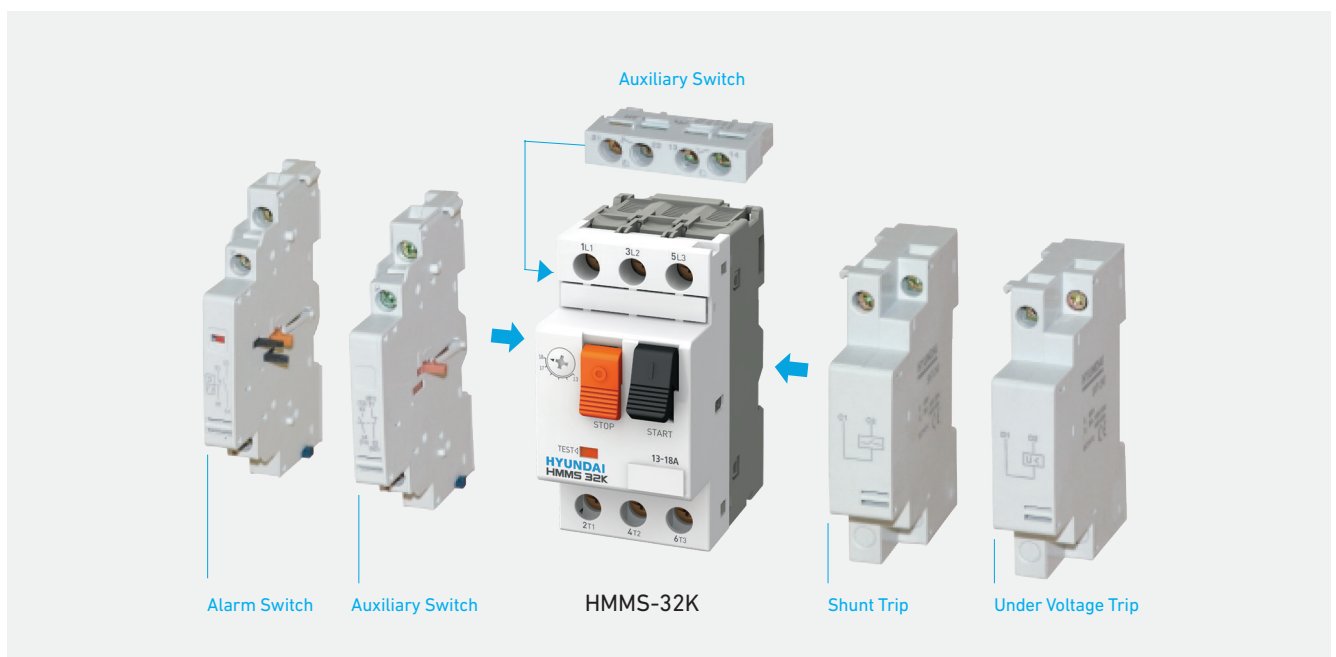

Technical Data

Mounting

35 mm Din-Rail for mounting

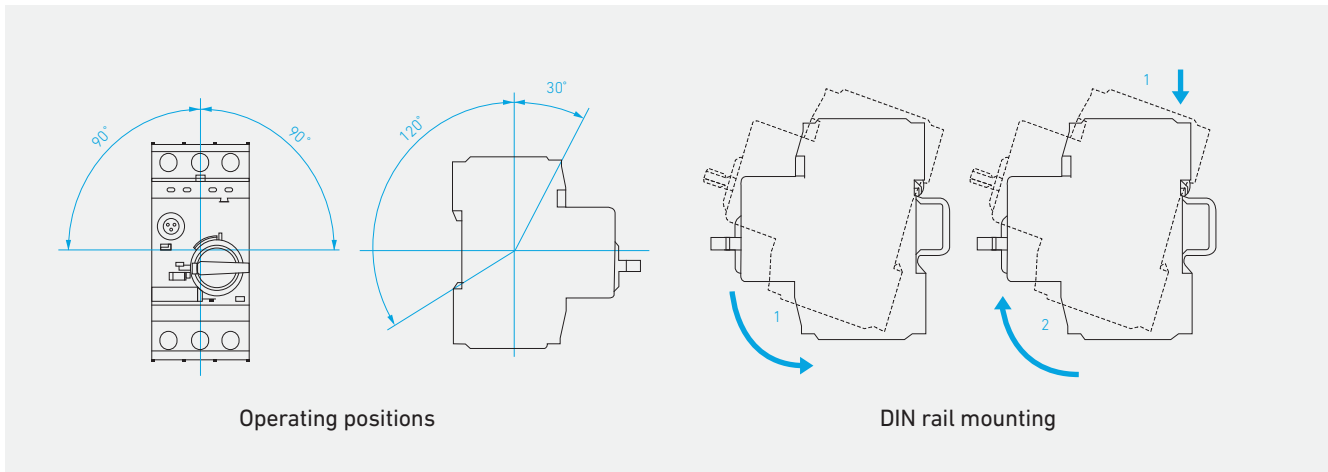

Caution for thermal adjustments

1. Keep the setting range as shown below.
2. Moving counterclockwise out of the setting range may cause the damage of the device.
3. Calibration by ambient air temperature



In case of using out of the standard air temperature range (-5°C~ +40°C) it needs to be calibrated by one point

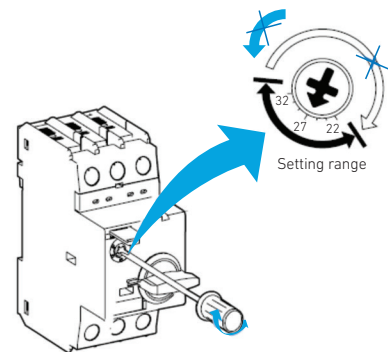

Dial setting method

Environment

Ambient air temperature

storage: -50... + 80 °C

operation: -20... + 60 °C

Ambient temperature compensation: -20... + 60 °C

Maximum operating altitude: 2,000 m

Protection degree: IP20

Shock resistance: 25 g

Vibration resistance: 5~150 Hz

Product side by side

When several products MMS32K/MMS32R/MMS80K are mounted side by side, the thermal trip setting I_r maybe need to be adjusted up to 1.1 I_n .

Don't exceed the maximum thermal setting I_r .

(ex: MMS32K 0010, thermal setting range: 6...10, don't adjust I_r above 10 A)

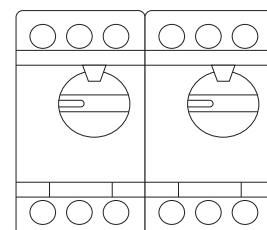

Terminals

Model	Terminal Screw	Applicable Wire Size (mm ²)	Ring Tongue Terminal (mm ²)	Screwing Torque (kgf.cm)
0.1-0.16 A	M4	1~10 mm ² (Hard cooper cable) 1~6 mm ² (Softcable)	Boreφ3.5, Maximum outsideφ 8.0	1.2 N.M
0.16-0.25 A	M4	1~10 mm ² (Hard cooper cable) 1~6 mm ² (Softcable)	Boreφ3.5, Maximum outsideφ 8.0	1.2 N.M
0.25-0.4 A	M4	1~10 mm ² (Hard cooper cable) 1~6 mm ² (Softcable)	Boreφ3.5, Maximum outsideφ 8.0	1.2 N.M
0.4-0.63 A	M4	1~10 mm ² (Hard cooper cable) 1~6 mm ² (Softcable)	Boreφ3.5, Maximum outsideφ 8.0	1.2 N.M
0.63-1 A	M4	1~10 mm ² (Hard cooper cable) 1~6 mm ² (Softcable)	Boreφ3.5, Maximum outsideφ 8.0	1.2 N.M
1-1.6 A	M4	1~10 mm ² (Hard cooper cable) 1~6 mm ² (Softcable)	Boreφ3.5, Maximum outsideφ 8.0	1.2 N.M
1.6-2.5 A	M4	1~10mm ² (Hard cooper cable) 1~6mm ² (Softcable)	Boreφ3.5, Maximum outsideφ 8.0	1.2 N.M
2.5-4 A	M4	1~10 mm ² (Hard cooper cable) 1~6 mm ² (Softcable)	Boreφ3.5, Maximum outsideφ 8.0	1.2 N.M
4-6.3 A	M4	1~10mm ² (Hard cooper cable) 1~6mm ² (Softcable)	Boreφ3.5, Maximum outsideφ 8.0	1.2 N.M
6-10 A	M4	1~10 mm ² (Hard Cooper Cable) 1~6 mm ² (Softcable)	Boreφ3.5, Maximum outsideφ 8.0	1.2 N.M
9-14 A	M4	1~10 mm ² (Hard cooper cable) 1~6 mm ² (Softcable)	Boreφ3.5, Maximum outsideφ 8.0	1.2 N.M
13-18 A	M4	1~10 mm ² (Hard cooper cable) 1~6 mm ² (Softcable)	Boreφ3.5, Maximum outsideφ 8.0	1.2 N.M
17-23 A	M4	1~10 mm ² (Hard cooper cable) 1~6 mm ² (Softcable)	Boreφ3.5, Maximum outsideφ 8.0	1.2 N.M
20-25 A	M4	1~10 mm ² (Hard cooper cable) 1~6 mm ² (Softcable)	Boreφ3.5, Maximum outsideφ 8.0	1.2 N.M
24-32 A	M4	1~10 mm ² (Hard cooper cable) 1~6 mm ² (Softcable)	Boreφ3.5, Maximum outsideφ 8.0	1.2 N.M
25-40 A	M8	2.5~25 mm ² (Hard cooper cable) 2.5~16 mm ² (Softcable)	-	3.5 N.M
40-63 A	M8	2.5~25 mm ² (Hard cooper cable) 2.5~16 mm ² (Softcable)	-	3.5 N.M
56-80 A	M8	2.5~25 mm ² (Hard cooper cable) 2.5~16 mm ² (Softcable)	-	3.5 N.M

Technical Data

Application for-3Phase Motors, AC-3

Rated Current (A)	Setting Range (A)	3-Phase [kW] (50/60 Hz)					
		AC230/240 V	400 V	415 V	440 V	500 V	690 V
0.16	0.1-0.16	-	-	-	-	-	-
0.25	0.16-0.25	-	0.06	0.06	-	-	-
0.4	0.25-0.4	-	0.09	0.09	-	-	-
0.63	0.4-0.63	-	0.12	0.12	0.2	0.25	0.37
1	0.63-1	-	0.25	0.25	0.5	0.5	0.55
1.6	1-1.6	-	0.37	0.37	0.55	0.75	1.1
2.5	1.6-2.5	0.5	0.75	0.75	1.1	1.1	1.5
4	2.5-4	0.5	1.5	1.5	2	2.2	3
6.3	4-6.3	1.1	2.2	2.2	3	3.7	4
10	6-10	2.2	4	4	5	5.5	7.5
14	9-14	3	5.5	5.5	7.5	7.5	9
18	13-18	5	7.5	7.5	9	9	15
23	17-23	6.5	11	11	11	11	18.5
25	20-25	6.5	11	11	15	15	18.5
32	24-32	10	15	15	18.5	20	22
40	25-40	10	20	20	25	30	30
63	40-63	20	30	35	40	50	60
80	56-80	25	35	40	50	55	60

HMMS32K/R

Thermal Magnetic Tripping Curve

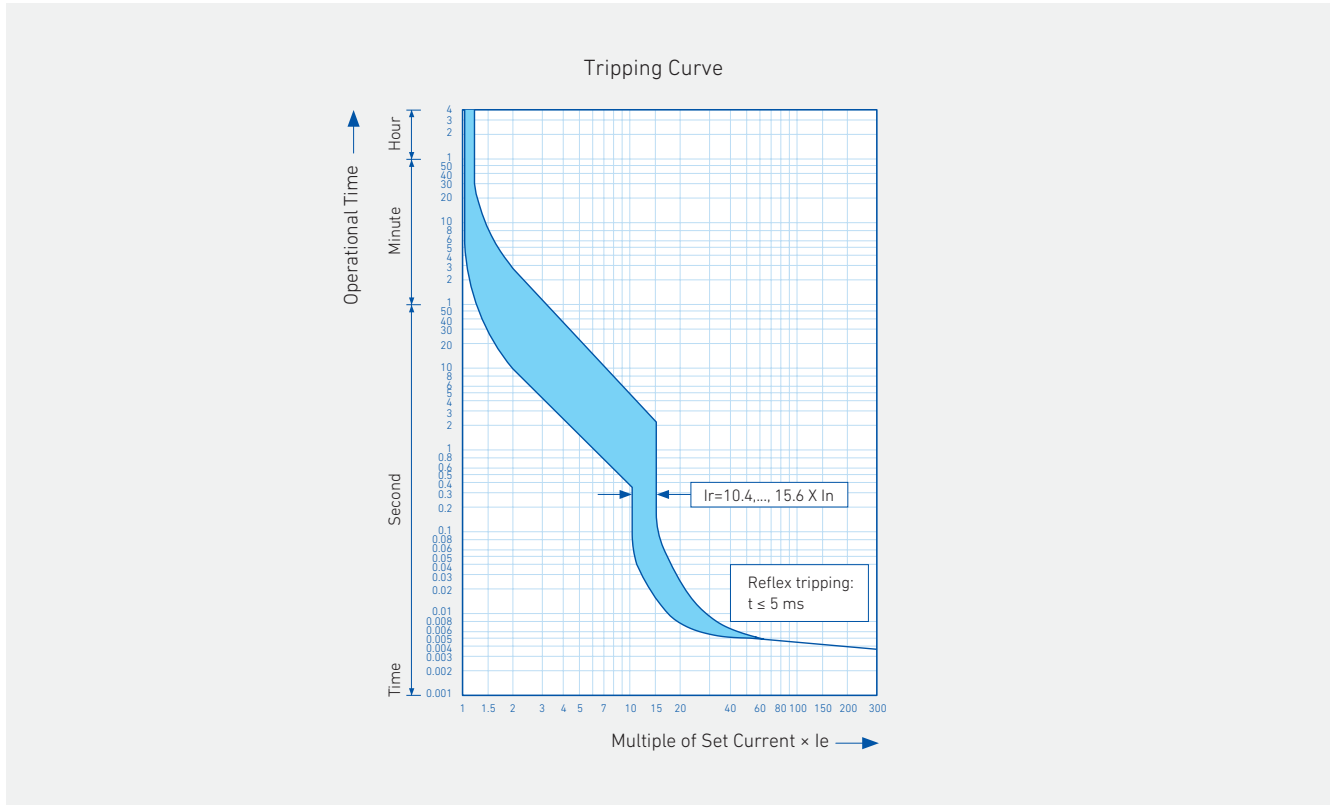

Current Limitation on Short Circuit HMMS32K/R

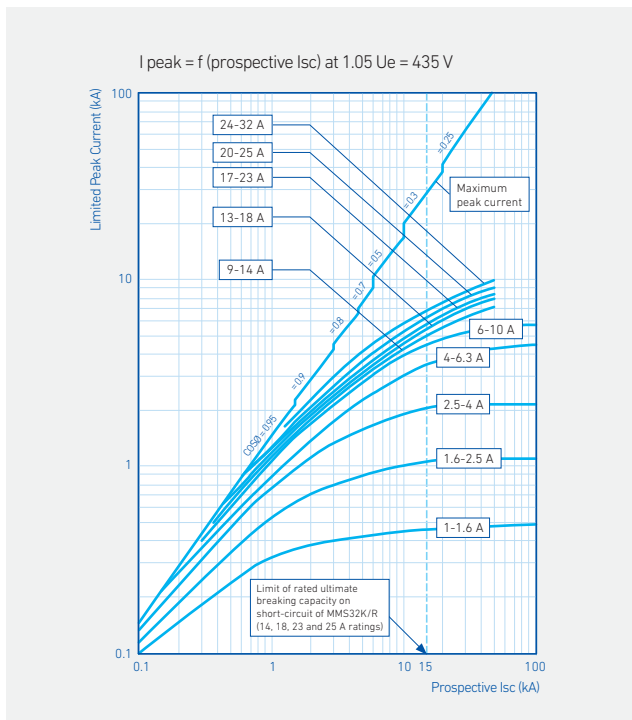

Thermal Limit on Short Circuit HMMS32K/R

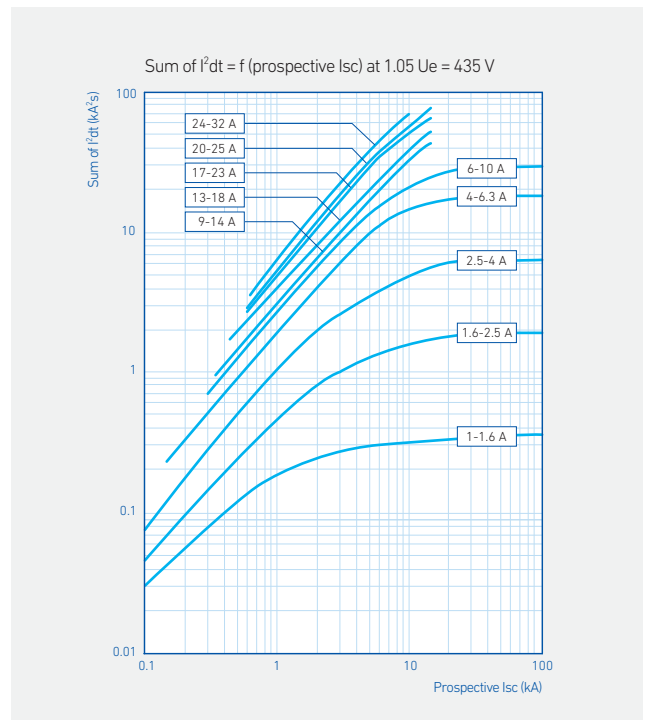

Technical Data

HMMS80K

Thermal Magnetic Tripping Curve

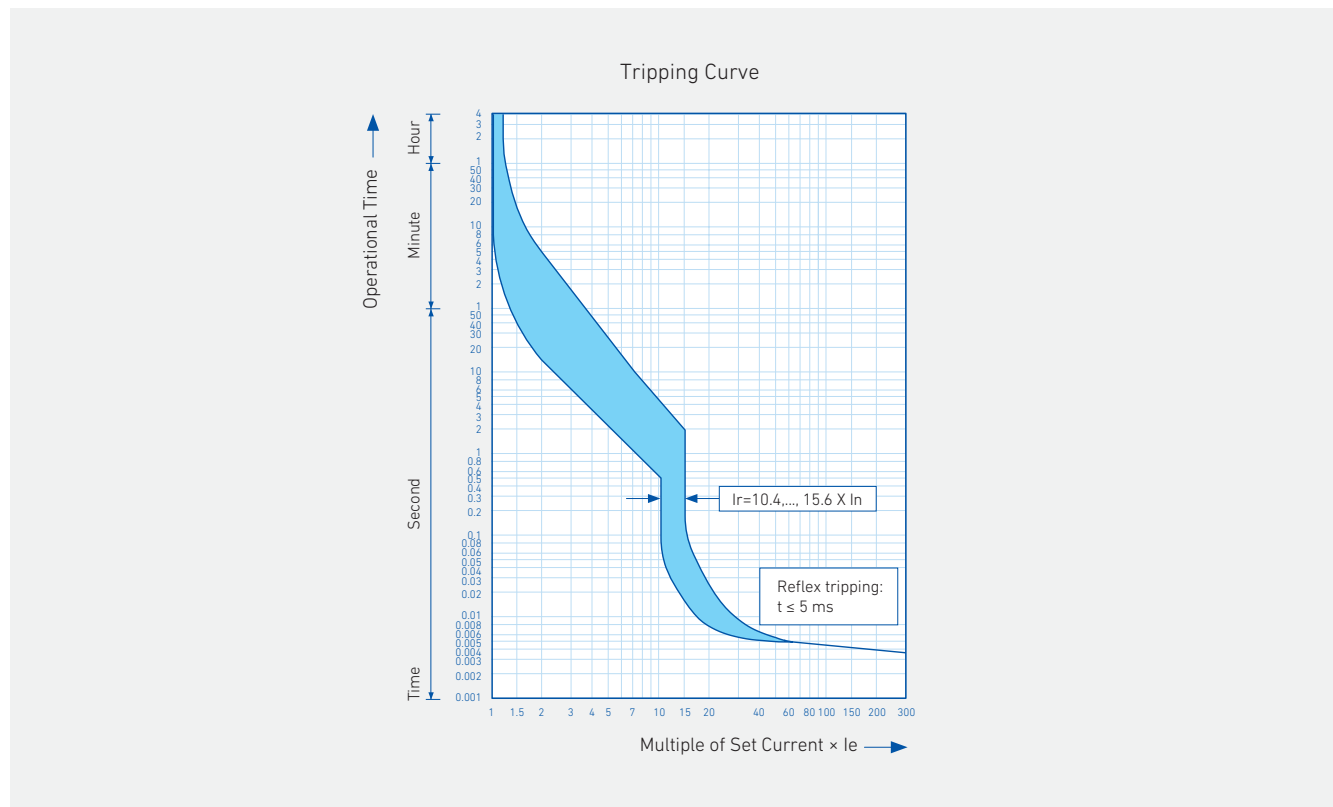

Current Limitation on Short Circuit

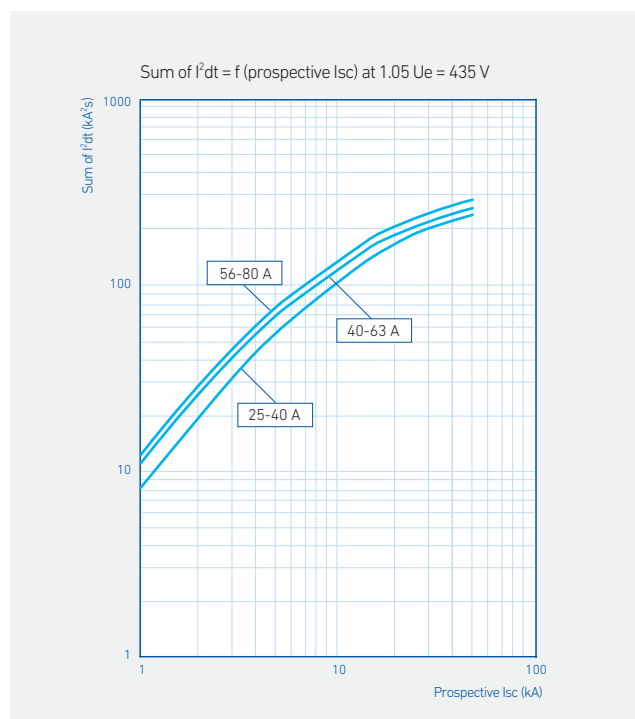

Thermal Limit in kA^2 in the Magnetic Operating Zone

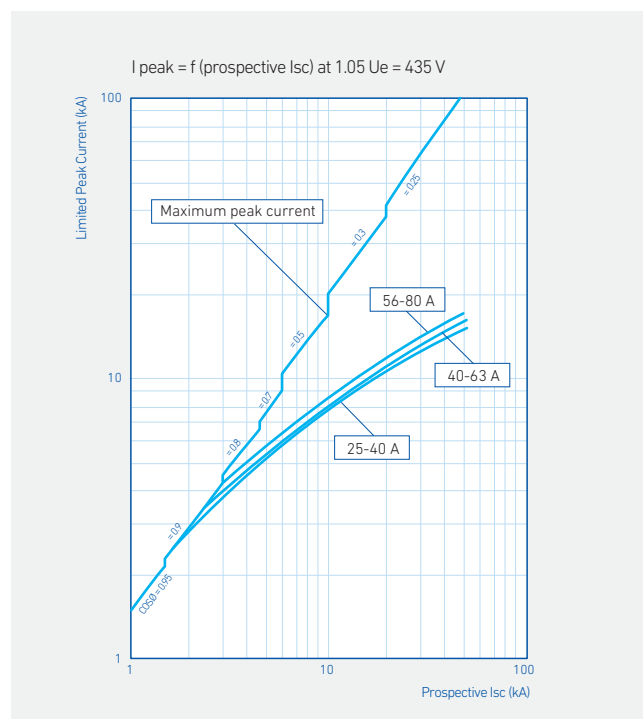

Dimensions

HMMS

HMMS32K

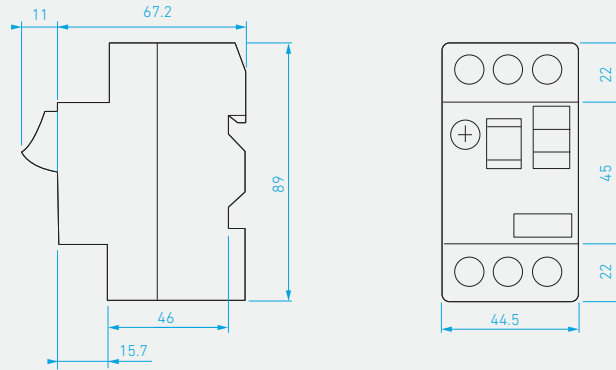

HMMS32R

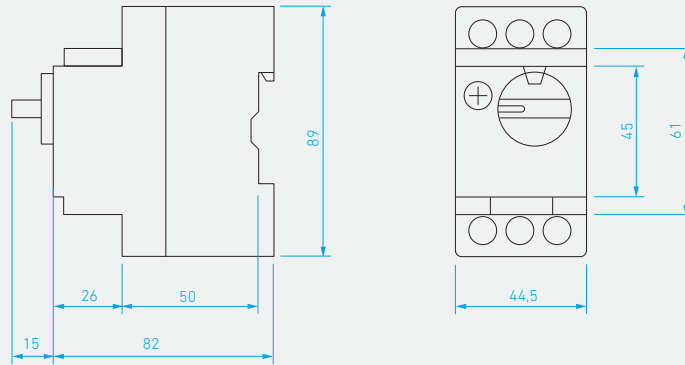

HMMS80K

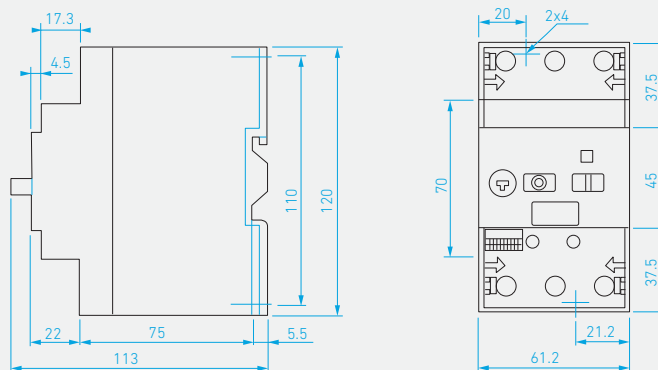

Dimensions

Accessories

Top Mounting: Auxiliary Switch

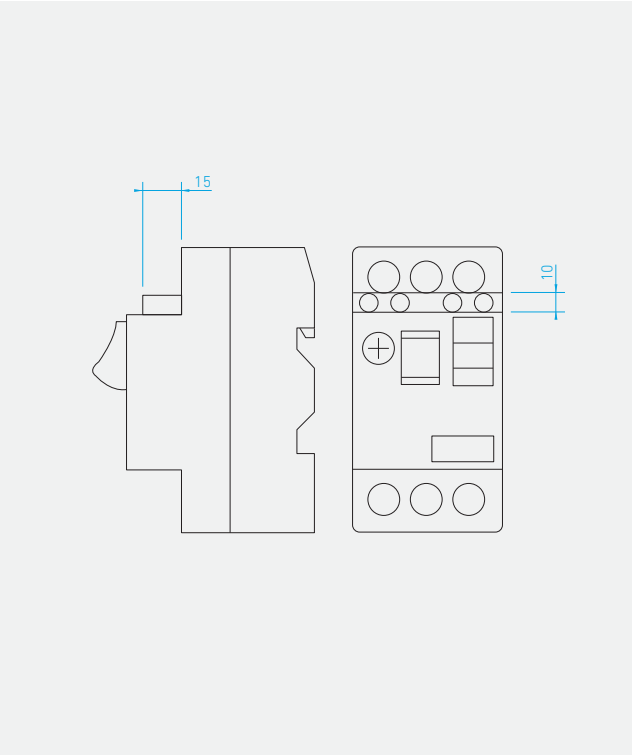

Side Mounting: Auxiliary Switch

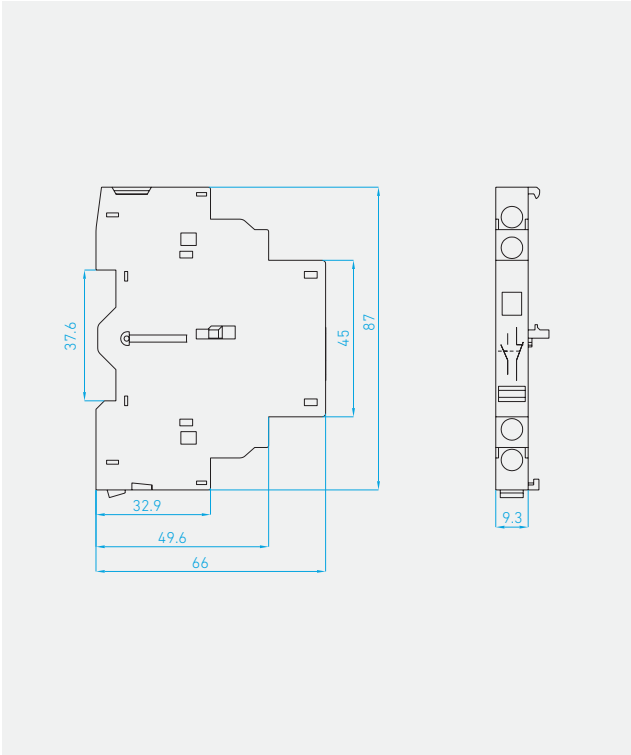

Side Mounting: Alarm Switch

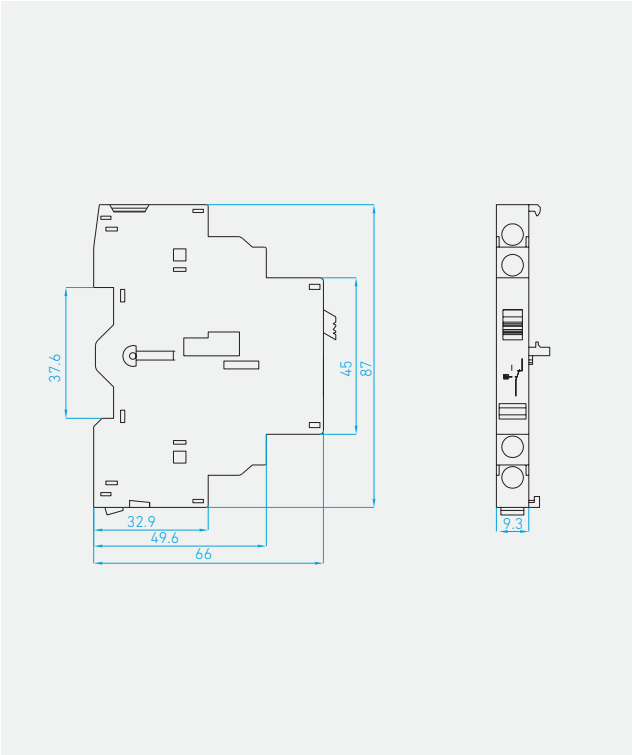

Side Mounting: Shunt Trip/UVT

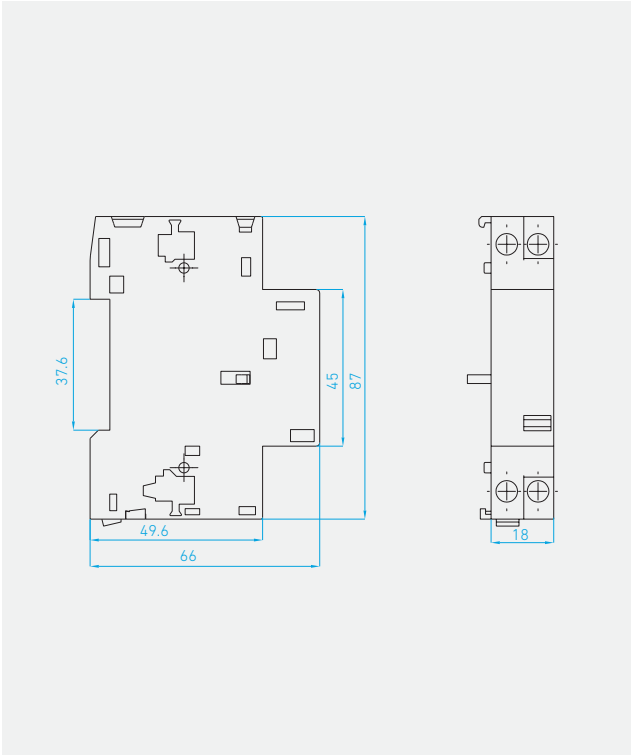

Enclosure

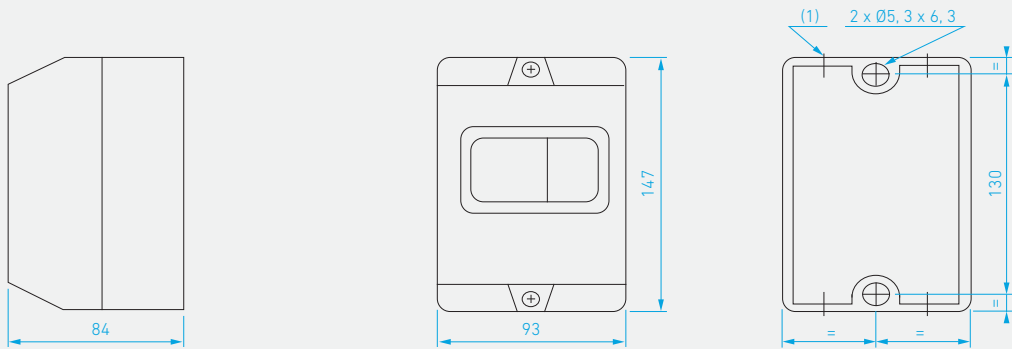

- (1) Top face: 2 knock-outs for ISO20/25 cable glands or Pg16 or 16 mm conduits.
 Bottom face: 2 knock-outs for ISO20/25 cable glands or Pg16 or 16 mm conduits.

Extension Handle

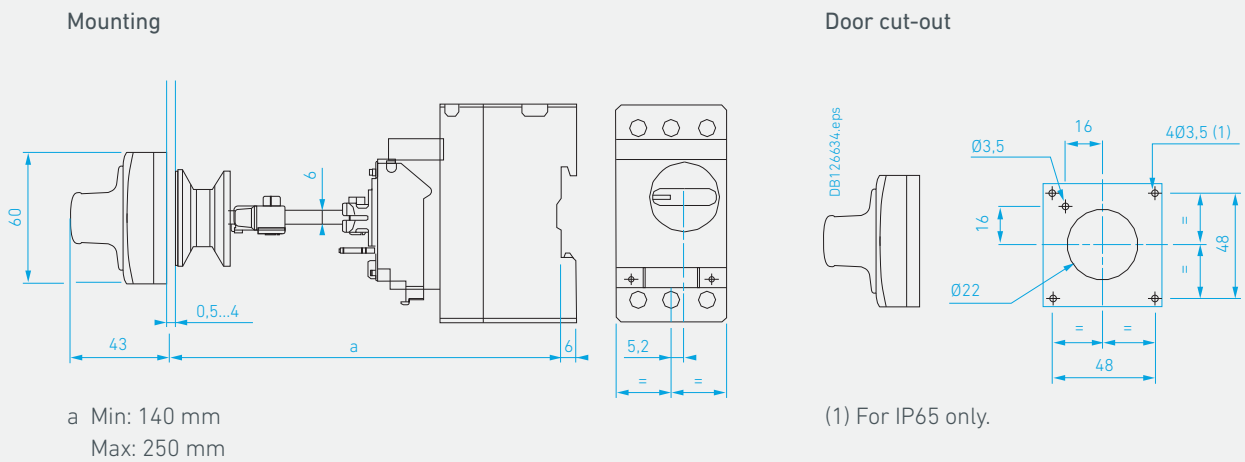

HMMS Ordering Information

Ordering Guidelines

Code	Rated Current Setting Range (A)	Unit (EA)	Handle Type
MMS32K 0P16	0.1-0.16	50	Push button
MMS32K 0P25	0.16-0.25		
MMS32K 0P40	0.25-0.4		
MMS32K 0P63	0.4-0.63		
MMS32K 1P00	0.63-1		
MMS32K 01P6	1-1.6		
MMS32K 02P5	1.6-2.5		
MMS32K 0004	2.5-4		
MMS32K 06P3	4-6.3		
MMS32K 0010	6-10		
MMS32K 0014	9-14		
MMS32K 0018	13-18		
MMS32K 0023	17-23		
MMS32K 0025	20-25		
MMS32K 0032	24-32		
MMS32R 0P16	0.1-0.16	50	Rotary
MMS32R 0P25	0.16-0.25		
MMS32R 0P40	0.25-0.4		
MMS32R 0P63	0.4-0.63		
MMS32R 1P00	0.63-1		
MMS32R 01P6	1-1.6		
MMS32R 02P5	1.6-2.5		
MMS32R 0004	2.5-4		
MMS32R 06P3	4-6.3		
MMS32R 0010	6-10		
MMS32R 0014	9-14		
MMS32R 0018	13-18		
MMS32R 0023	17-23		
MMS32R 0025	20-25		
MMS32R 0032	24-32		
MMS80K 0040	25-40	14	Push button
MMS80K 0063	40-63		
MMS80K 0080	56-80		